

# Hydraulic Parallel Movements and Synchronisation

ir. J.G. Gruijters

September the 15th, 2021

## Abstract

Some designs require synchronisation or parallel movements of actuators. This article shows some examples of how synchronisation can be achieved and gives an estimate of their accuracy. The first option is to evaluate mechanical solutions, as these cannot lose synchronisation and do not require to be reset. There are hydraulic solutions to get synchronisation between cylinders, although the accuracy and costs will vary. There are hydraulic circuits to synchronise actuators. Furthermore, flow dividers based on orifices, rotary flow dividers and linear flow dividers are available.

Hydraulics is used in many industries like offshore, mobile hydraulics or hydraulic presses. In some cases it is required to synchronise the movement of two or more cylinders. One example is when two cylinders are used to move a large mass. Especially when the cylinders are mounted close together, the maximum difference in stroke is often limited. For such applications measures must be taken to ensure the parallel movement. This article is made to give a short overview of the possibilities to guarantee parallel or synchronised movement.

nisation is not required at all. When this is possible and achievable, this should be considered as first option, as these options are very robust. Beyond robustness, a hydraulic or other means for synchronisation on a very stiff mechanical structure might even lead to skewing behaviour. Thus a stiff mechanical system will work fine without, but can skew other synchronisation methods are used.

Another accurate and simple mechanical solution for the parallel movement is a parallelo-

## 1 Mechanical synchronisation

The first but often the simplest method, is to make the guiding of the system strong enough and the construction stiff enough, that synchrono-

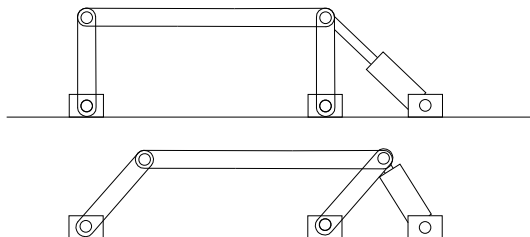

Figure 1: The simplest mechanical solution: a parallelogram.

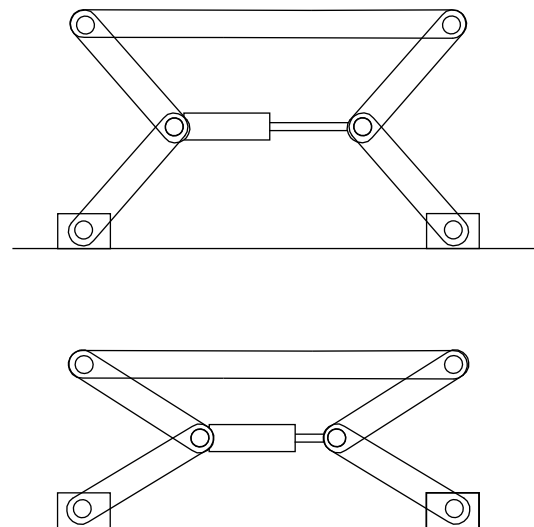

Figure 2: A mechanical construction which is also often used in a jack.

gram. This will give almost perfect parallel movement without high costs. The simplest version is shown in figure 1, although this has some limitations in height, so this is only shown here to show the working principle. A principle much like the parallelogram is a jack-like construction, as shown in figure 2. Dependent on the mechanical design, the jack-like structure might require a higher force of the hydraulic cylinder compared with the mechanical load, but often this is achievable with a high working pressure or a relative large diameter of the cylinder. This is often not a problem, as there is usually sufficient space to fit the cylinder.

The two examples above are both for translations, but sometimes the rotation is required to be synchronised. One example of this application is a gripper which needs to grab a pipe (for instance a drill pipe on board a drilling vessel) and center it to be able to make a connection with another pipe. In this case the synchronisation of the right half of the gripper needs to be accurate with the left half of the gripper, otherwise the pipe is not centered. This can be done with a mechanical solution, as shown in figure 3. On the left side of figure 3 the cylinder is extended to grip and center a pipe for instance. On the right of figure 3 the the cylinder is retracted and the gripper is in open position.

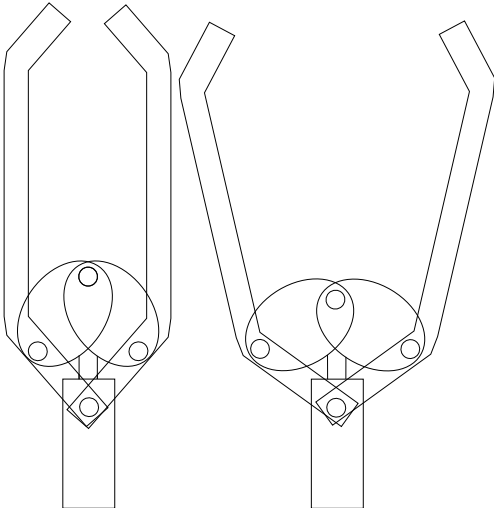

Figure 3: A mechanical construction for a gripper for a pipe.

The main advantage of mechanical solutions is that the synchronisation cannot be lost, it does not require to be reset and is in many cases not as expensive as hydraulic solutions. This should be taken into consideration when designing a system where synchronisation is required.

A drawback of mechanical solutions, is that the structure can skew. Luckily, there is a simple formula for skewing [4], which states that a structure is likely to skew when:

$$L < 2 a \mu \quad (1)$$

where  $L$  is the conductance length,  $a$  is the perpendicular arm of the force to the rail and  $\mu$  is the coefficient of friction. Note that two individually controlled actuators which are mechanically rigidly coupled also have a high chance of skewing, as stated before.

For the purpose of this article, no further mechanical examples will be shown, as the main focus will be on the hydraulic solutions, including the advantages and drawbacks. Furthermore, every mechanical design is different and will have its own challenges (available space, external forces, required accuracy, etc.), which means that the engineer will have to be creative to find a mechanical solution.

## 2 Hydraulic circuits

Using a separate device like a flow divider to achieve parallel or synchronised movement might not always be preferred. Especially for larger flows the costs can become high and the space claim of the flow divider is then probably large as well. Therefore, other options using hydraulic circuits are available to the engineer. In this chapter the commonly used methods are shown. These methods do not show full solutions, but should inspire the creativity of the engineer.

One of the main issues for hydraulic circuits is bleeding air from the system. Especially with hydraulic isolated parts, so parts which cannot be flushed properly, are difficult to bleed.

### 2.1 Use cylinders at both sides

One simple solution, when possible, is to place one cylinder at a different side of the load. When

the hydraulic rod volumes are connected, the cylinders are hydraulically forced to move simultaneously. An example is shown in figure 4. The largest deviations are mainly caused by the compressibility of oil, so the accuracy is high. The downside is that the two cylinders act as one cylinder and thus require a larger cylinders. The pressure on the rod sides are equal, while one bottom side is pressurised, while the other is connected to tank. This means that although two cylinders are required, the effective force is equal to one bottom side being pressurised.

The example of figure 4 is too simplistic to be built directly. Due to storage and temperature

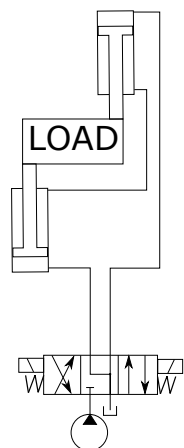

Figure 4: To move the load, the two cylinders are placed at different sides, while the rod areas are connected together.

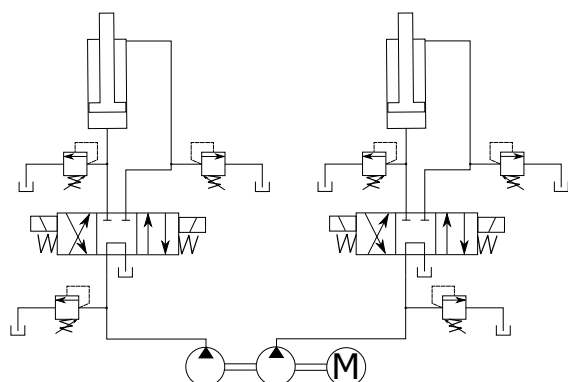

Figure 5: Each cylinder has a separate pump in order to achieve synchronised movement.

changes, the rod side will require at least a relief valve and a check valve with tank connection. Furthermore, for commissioning and compensation of inaccuracy, the rod side will require a fill and drain valve.

## 2.2 Multiple pumps

One method to achieve synchronised movement is to use separate fixed displacement pumps, as shown in figure 5. As the pumps have the same displacement per revolution and are mechanically coupled, the flow from the pumps is equal. This results in synchronised movement, as long as the directional control valves are shifted simultaneously.

The accuracy is influenced by the pressure in the cylinders. If one actuator is carrying more load than the other, the pressure is higher and the volumetric efficiency of that pump will be less, creating small deviations in the stroke. Furthermore, the spool valves have a leakage which is proportional to the pressure. The effect of small deviations due to leakages will be even larger when hydraulic motors are used as actuators, as these also have a volumetric efficiency. Therefore, this solution requires the strokes of the actuators to be reset once every while, for instance by going to an end of stroke position.

The electrical motor driving the pumps is normally a frequency drive, meaning that the rotational speed can be ramped up and control the rotational speed, and thus the flow. This means that this system does not require any flow controllers.

## 2.3 Proportional hydraulics

Another option to keep actuators synchronised, is by adapting the oil flow to the actuators based on the difference between the cylinders. This can be done with flow controllers, but often a proportional directional valve is chosen. An example is shown in figure 6. This solution requires that the speed setpoint of the cylinders is used in a feed forward to control the direction of the cylinders. The position of the actuators is measured, which means that the difference between the actuators is also known. Based on this error, one proportional valve will open slightly more or the

other proportional valve closes slightly, to compensate for the stroke difference. The position feedback will require a proper measurement to prevent large measurement noise, which will affect the accuracy of the system.

The accuracy of a proportional hydraulic solution is highly dependent on the design and environment. Advised is to use a 2 or 3 way pressure compensator over the proportional valves to keep the pressure drop over the proportional valve constant. The flow through the proportional valve is dependent on the pressure drop over the valve, so a varying pressure drop will increase the stroke differences. Furthermore, a  $-$ controller requires an error to respond, and the I-action of a PID-controller requires time to react. This means that although in many cases the accuracy will be sufficient, this method will not be the most accurate solution.

Another remark is that proportional valves are non-linear near the center position (dead-band). This means that the proportional valve will introduce problems when this feedback loop is also active when the proportional valve is in the center position. If accurate control near the center position of the proportional valve is required, the engineer should consider the more expensive and sensitive servo valves.

## 2.4 Connect cylinders to act as one

In figure 7 there are two examples of hydraulic circuits to create synchronised or parallel movement. The solution on the right requires one

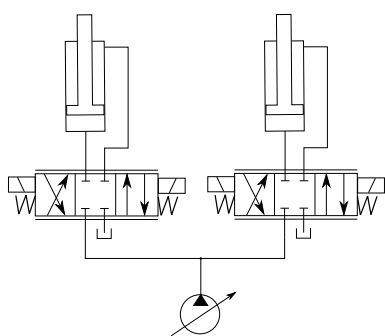

Figure 6: A control loop controls the proportional valve, keeping the stroke difference within limits.

extra cylinder, which is not carrying any load, to compensate for the volume difference between the bottom and rod side of the two load-carrying cylinders. This is a costly method, as this design requires one additional cylinder to be bought, which will not contribute to supporting the load. That is why on the left an option with double rod cylinders is shown. There is no volume difference (theoretically) between the two cylinders and therefore this option does not require the extra cylinder. To be able to fully retract and extend, one 4/2 directional control valve is installed to fully retract both cylinders and reset any possible stroke difference. The option with the double rod cylinders will require however a relief valve and a suction valve for storage situations with temperature changes and require a measure to compensate for the minor machining tolerances of the two cylinders.

The accuracy of this type of solution is high, although it does require some space and will add some weight to the design. Furthermore, due to the compressibility of oil, there will be some small differences in stroke.

## 3 Flow dividers

A common way to achieve hydraulic synchronisation or parallel movement is by using flow dividers. In general there are three types: orifice based flow dividers, rotary flow dividers and linear flow dividers. These three types will be

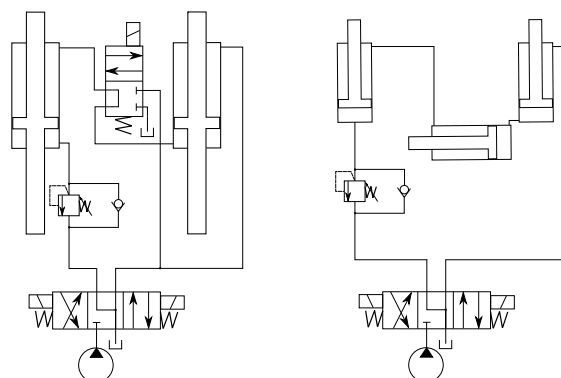

Figure 7: Two examples how to connect hydraulic cylinders to create synchronised movements.

explained in separate subsections.

But to start: Why are flow dividers required? It is possible to connect all actuators to one valve (in Dutch: 'op één bad'). Lets examine a case with cylinders: once the directional control valve is shifted and the pump is connected to the cylinders, the pressure will rise until the cylinder with the lowest load starts to move due to the rising pressure. As more oil is added, the cylinder with the lowest load will keep extending, while the others do not move at all. Due to the movement of the cylinder with the lowest load, this cylinder will probably start to carry more load, which means that the pressure in the system will rise. When the pressure is high enough for another cylinder to start moving, two cylinders will start to move and the flow will divide over these two cylinders. But, dependent on the mechanical design and stiffness, it is also possible that first one cylinder will move until the end of stroke position is reached and then the other will start to move. This means that without measures, there is no synchronisation between the actuators.

### 3.1 Orifice flow dividers

The most simplistic flow divider is an orifice flow divider. Orifices are flow control valves, but the flow of a normal orifice is dependent on the pres-

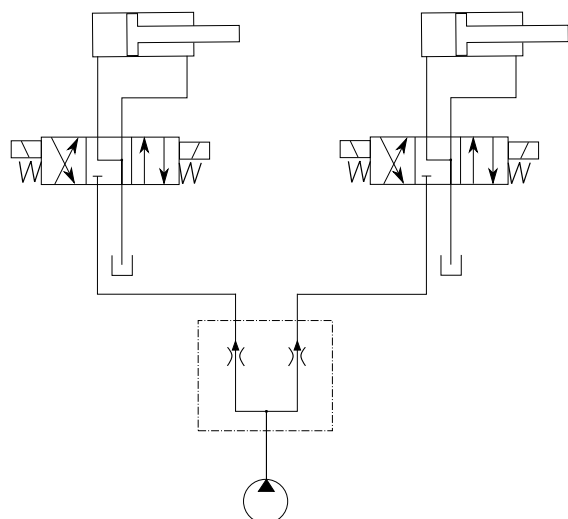

Figure 8: A flow divider based on two pressure compensated orifices.

sure drop over the orifice. Therefore, pressure compensated orifices are used in the flow divider, to make the flow pressure independent. An example of an orifice flow divider is shown in figure 8. A limitation of this type of flow divider is that in general it will only split the flow into two lines. Adding more lines would decrease the accuracy of this flow divider.

In the specifications these types of flow dividers promise pretty good accuracy (inaccuracy as low as 2 or 3% per cylinder), but in practice it is not possible to stay below a 10% deviation in stroke of both cylinders. This has to do with the fact that a lot of parameters influence the flow over an orifice, like pressure difference in the cylinders, viscosity, temperature, etc. Especially when the maximum flow of a flow divider is not reached, the accuracy will decrease, which is why these types of flow dividers also state a minimum amount of flow. This means that when this type of flow divider is used, the cylinders should get to the end of stroke position very often, to reset the difference in stroke due to the inaccuracy. How often the cylinder would have to get end of stroke is dependent on the inaccuracy which is allowable.

Note that (at least some of) these types of flow dividers cannot 'reset' the stroke of cylinders or motors. This means that once the cylinder of one port reaches end of stroke, the other will stop as well, although it is not end of stroke. This means that this type of flow divider needs some sort of correction method to restore the stroke difference. This means in most cases a second way to add or extract oil from each cylinder or motor.

When using this type of flow divider for hydraulic motors, the motors themselves do not have an 'end of stroke' position. So in this case the engineer should make it possible to align the two motors again, because otherwise the difference between the two motors will keep increasing. The accuracy of an orifice flow controller applied to motors will be lower than for cylinders, as the motors have some leakage themselves. The motor with a higher pressure will have a higher leakage and thus a lower accuracy. This means that in that case the motors without a reset of the parallel movement will have approximately the same velocity, but their positions are no longer

synchronised.

The engineer should keep in mind that the orifice flow divider has a pressure drop over the valve due to the pressure compensator and the orifice. This means that at the maximum flow the maximum pump pressure is not available at the actuator. This means that when the actuator needs to deliver the full force/torque at the maximum speed, the engineer should increase the pressure at the pump or select a larger actuator such that the lower pressure will still generate sufficient force/torque.

This type of flow divider is available for flows up to  $240L/min$  [1] and can be chosen to have specific flow dividing: from 50%-50% over the two ports to for example 40%-60% or 33%-67%<sup>1</sup>, which can be useful when actuating different cylinders or for instance the bottom side of one cylinder and the rod side of another cylinder. Another advantage is the price<sup>2</sup>: the flow divider up to  $240L/min$  costs less than €400,- and the manifold is approximately €250,-, which is less than the other options which will be presented here. Besides Sun Hydraulics there are other manufacturers (Jahns, Bucher and Hydac amongst others) that have this type of flow dividers in their standard catalogues.

These types are also available in flow dividing-combining controller, meaning that the flow can go in both directions (which is not possible with a regular orifice flow divider).

### 3.2 Rotary flow dividers

A rotary flow divider is basically a couple of hydraulic motors that are mechanically coupled. The mechanical coupling ensures that all motors rotate at the same speed and have the same oil displacement. Example of a hydraulic diagrams with a rotary flow divider are shown in figure 9. Similar to hydraulic motors, the rotary flow dividers have internal leakage. Some flow dividers require a separate (very low pressure) drain line, others (mostly small flow dividers) have a hous-

<sup>1</sup>This flow dividing ratio is specific for a flow divider. When this needs to be changed, the flow divider must be exchanged with another flow divider which has the other dividing ratio.

<sup>2</sup>The price mentioned here is only to give the reader an idea of the order of magnitude of the costs.

ing which can withstand the design pressure. The internal leakage leads to an inaccuracy, although normally the accuracy is higher than for orifice flow dividers. Due to the internal leakage the rotary flow controllers have a minimum flow requirement. To limit the rotational speed of the flow divider there is also a maximum flow.

Unlike the orifice flow dividers it is possible to get rotary flow dividers for multiple actuators, up to twelve actuators, although the larger flow dividers, or with more actuators, the flow dividers become specials, which will also reflect in the price.

The rotary flow dividers can magnify the pressure in one cylinder, which is why relief valves must be installed at the actuator side of the flow divider. The magnification is caused by the synchronisation of the flow. If one cylinder already is taken load, while the others are not. This means that the pressure in one cylinder will rise, while the others do not. The pressure in the load bearing cylinder can be magnified by the factor which is equal to the amount of actuators connected to the flow divider.

The inaccuracy of rotary flow dividers is approximately from just below the 1% (small, radial flow dividers) to roughly 4% according to the specifications. This will be slightly less when the flow divider is not running at an optimal rotational speed. This means that rotary flow dividers still require a method to reset the difference in stroke

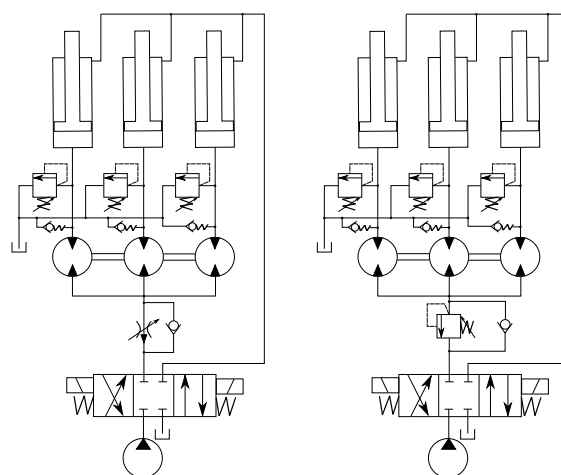

Figure 9: A rotary flow divider.



once every while. The simplest method for cylinders is to allow all the cylinders to get to the end of stroke position. As example: review figure 9 in the case of extending the cylinder. Lets assume that the cylinder in the middle is slightly lagging behind. This would result in the other two cylinders being at the fully extended position, while the cylinder in the middle is not. The pressure in the other two will rise and the relief valves will open, allowing some oil to escape. This means that the rotary flow divider can still rotate and the middle cylinder can extend fully as well, as long as the pressure from the pump is sufficient to rotate the flow divider against the pressure in the cylinders. When retracting with misaligned cylinders, the two cylinders which are running ahead will be fully retracted before the cylinder in the middle is fully retracted. This means that the rotary flow divider can cause a vacuum in these retracted cylinders, as it removes oil from the cylinder while the cylinder cannot retract anymore. Therefore, check valves are installed to allow oil from the tank line to enter the flow divider, to prevent the vacuum and cavitation.

For cylinders which can start to move due to their own weight or due to their loads, it is important to protect the rotary flow divider against too high rotational velocities. This would damage the rotary flow divider, but more importantly it would mean that the load is lowered in an uncontrolled way. Therefore it is important to have a 'metering out' throttle check valve installed, as this valve limits the flow and thus the speed. When holding the load is even more crucial, the throttle check valve should be exchanged with a relief valve and a check valve, as shown in figure 9 on the right. This will make sure that the pressure of the three cylinders combined is always equal to the relief valve setting during lowering. Sea fastening or storing a load on the flow divider for a longer period of time is not advised, as the flow divider has some leakage. For storage a mechanical construction should be made.

The rotary flow dividers require a pressure drop over the flow divider in order to work. As stated before, the rotary flow divider is like combining hydraulic motors while mechanically locking them together. The motors will have some friction, which means that the supplied pressure

should always be higher than the combined pressure in the cylinders in order for the flow divider to rotate.

There are some special things to consider when working with the rotary flow dividers. First of all, the rotary flow dividers can have difficulties during start-up when the pressure in the cylinder is already high. This is especially true for the smallest flow dividers. If this is likely to occur, the engineer can install check valves to hold the load in the cylinder and release the pressure in the flow divider to tank, although the actual solution from case to case is specific for the design. A second issue which is regrettably forgotten too often, is that some rotary flow dividers require their housing to be filled before commissioning starts. If this is not done properly, the flow divider is running dry for too long until the internal leakage has filled the housing with hydraulic oil. This is especially true for radial type rotational flow dividers, but this should be checked for all flow dividers before commissioning starts.

The rotary flow dividers which are available on the market, can handle up to  $550L/min$  per actuator [3], although large flow dividers are often not standard for high pressure classes. Larger flow dividers or flow dividers for a higher design pressure can be ordered, but these are considered specials and will have a higher price tag. The costs are very dependent on the size and type of flow divider: small flow dividers are somewhere in the range of €300,-, while larger flow dividers can be up to ten times as expensive. Besides Jahns there are other manufacturers that deliver rotary flow dividers, like Hawe and Bucher for instance.

For the orifice flow dividers, a special type was required to have a flow combining function as well. Most rotary flow dividers can run in reverse, which means that no special options are required when a flow divider-combiner is required.

### 3.3 Linear flow dividers

The linear flow divider, often also called a volumetric divider, is basically a couple of cylinders mechanically linked together. This means that the stroke of all cylinders will be equal. As there bore and rod are equal, they will displace the same volume of oil over the stroke. As the internal leakage of cylinders is negligible, the accuracy

is very high. This means that this type of flow divider does not require to be reset as often as the other flow dividers and that, besides to compensate friction, there is no pressure limitation other than a design pressure. Smaller linear flow dividers up to 50ltr are available on the market [2], but larger flow dividers can be custom designed. The total amount of flow is limited for this type of flow controller, as the linear flow controller can hit an end of stroke position. Therefore, it is common to make the volume of the linear flow divider 10% to 15% larger than the required volume, to make sure that the actuator can reach the end of its stroke.

Similar as for the rotary flow divider, the linear flow divider can magnify the pressure in one cylinder. Therefore, relief valves are required at the actuator side of the flow divider.

The accuracy of the linear flow controller is high. The accuracy is theoretically dependent on many mismatches (seepage of the seals, machining tolerances), but in practice this is hardly measurable (especially for larger flow dividers). The largest factor for inaccuracy is the bulk modulus of the oil, which comes down to the compressibility of oil. This means that these types of flow dividers have an inaccuracy which is an order of magnitude of 100 smaller than rotary flow dividers, which means it is between a hundredth and a tenth of a percent (0.01% - 0.1%). Slow speeds are possible as well with the linear flow divider, so theoretically there is no minimum speed.

If very low speeds are required the flow divider should have special low friction seals to prevent stick-slip. The flow is mainly limited to the maximum speed of the seals, which are comparable with piston speeds of cylinders.

One difficulty with linear flow dividers is bleeding air from the system. Air in the volume between the cylinder and the flow divider will result in inaccuracies, as air is compressible. Additionally, the air can result in vibrations. As the system normally cannot be flushed, it becomes difficult to decently bleed air from the system. This should be handled during the design phase of the system.

The pressure drop over the flow dividers is, in comparison to the other types of flow dividers, low. For smaller (standard) linear flow dividers the pressure drop is in the range of 5bar to 10bar. For larger flow dividers, it is dependent on the actual size and used seals.

The costs of the linear flow divider is normally higher than for the orifice and rotary flow dividers. The actual costs vary a lot with the size and bore of the flow divider. Besides Jahns there are other manufacturers which are able to make the linear flow dividers, like Lemacher Hydraulik and Hydac, but also cylinder manufacturers are able to manufacture this type of flow dividers.

## References

- [1] Sun Hydraulics. *FSFD-XAN*. Flow divider, 240lpm.
- [2] Jahns. *MZB 280*. Multi-chamber volumetric divider, 50ltr displacement.
- [3] Jahns. *MT-GM6*. Rotary flow divider, 550lpm.
- [4] WikipediA. Schubladeneffekt. *Wikipedia*, 2018.

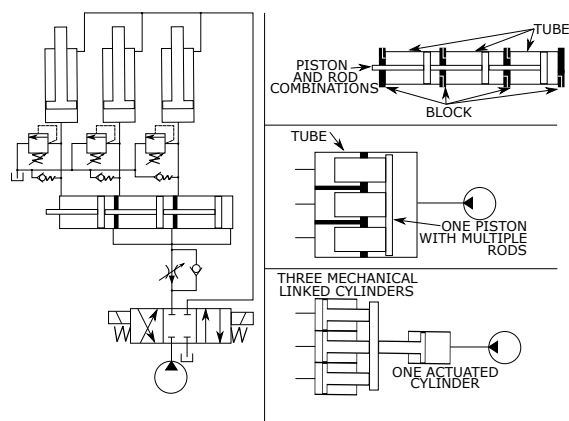

Figure 10: A linear flow divider, with a concept sketch of three possible lay-outs.